



# I-TRONIK

## XSD-701-53 Dry Cabinet



### Outstanding performance

The XSD series has an outstanding performance for drying moisture sensitive components and pcb's.

The 53 series offers you the possibility to remotely operate and control your drying cabinet (s).

The dynamic drying unit of the 5000 series reaches very reliable low humidity values of 0,5% RH and automatically regenerates if necessary.

As a result of an insulated double metal sandwich construction a precise temperature of 60°C can be reached with a very low power consumption.

A radial fan and heater supports the drying process and realizes an equable temperature and moisture level in the cabinet. The relevant process data is obtained by use of an accurate Rotronic sensor.



**I-TRONIK S.R.L.** - Macchine e prodotti per l'industria elettronica  
Via dell'Artigianato, 20 - 35010 - Peraga di Vigonza (PD)  
Tel. +39.049.895.2300 - Fax +39.049.893.4822 - P.IVA 01443020282  
commerciale@itronik.it - [www.itronik.it](http://www.itronik.it)

Totech Europe BV  
De Linge 28  
NL-8253 PJ Dronten  
[www.totech.eu.com](http://www.totech.eu.com)

Phone: +31 (0) 321 330239  
Fax: +31 (0) 321 330254  
K.v.K: Lelystad 390 86417  
E-Mail: [info@totech.eu.com](mailto:info@totech.eu.com)

V.A.T.: NL813341887B01  
IBAN: NL83Rabo0145683443  
B.I.C./Swift: RaboNL2U  
Bank: 1456.83.443



## Features

- **User friendly handling**
- **ESD features**
- **Insulation**
- **Data logging sensor**
- **Sensor read out**
- **Touchscreen read out**
- **Interior lighting**
- **Door & humidity alarm buzzer**
- **Leveling out**
- **Lockable doors**
- **Sliding shelves**
- **U 5000 series drying unit**
- **Rotronic sensor**
- **Power supply**
- Multifunctional full color touchscreen with easy menu structure
- Norm (IEC 61340-5-1)  
ESD stainless steel body (<math>10^3</math> Ohm/sq).  
Conductive glazing (in- and outside <math>10^3</math> Ohm/sq).
- 60 mm polyurethane sandwich construction
- Integrated data logger over sensor with standard 2000 measuring points.
- RS 232 interface (optional software required)
- Ethernet interface for communicating touchscreen (see data touchscreen)
- Low power consumption LED lighting
- Longer dooropenings are detected, high RH levels are detected
- Adjustable legs
- Every door can be locked separately with a key.
- In height adjustable sliding shelves (5 pcs)
- <math>< 0.5\%</math> RH, made in Germany
- Precision sensor, accuracy <math>+/- 0,8\%</math> RH, <math>+/- 0,3\text{ }^\circ\text{C}</math>
- Power cord 5 meter with IEC plug

## Benefits

- **Drying time**  
(see reference table)
- **Recovery time after door opening**
- **Temperature stability**
- **Temperature setting**
- **Energy saving consumption**
- **Remote control and operation**
- **Wifi**
- **IPC**
- **European Quality**
- **Maintenance**
- Level 3 component , 1,4 mm = 18 hours (60°C / 1% RH)
- <math>< 6</math> minutes
- The same temperature level throughout the drying cabinet as a result of the use of a radial fan in combination with ventilation and heating canal in insulated sandwich construction. Accuracy <math>+/- 2\%</math>
- Heating up to 60°C
- As a result of a Dynamic dry unit, sandwich construction with insulating Polyurethane.
- Touchscreen can be controlled from a distance through ethernet
- Optional
- According to IPC-Jstd 033C
- Made in Germany
- Easy to service, low maintenance

## Benefits touchscreen



- 7"full color HMI touchscreen
- Actual graphics of humidity and temperature
- History graphics from past 90 days
- Status from Dry unit and cabinet (dry unit fan, door, dry unit heater)
- Event log with information: start regeneration, temperature, login etc.
- Password protected for admin and operator
- Different settings for regeneration possible
- Firmware update by SD-card
- Global service through Ethernet
- N2 adjustment through touchscreen



## Technical Data Cabinet

- External dimensions: (W x H x D) 700 x 1930/2110 x 808 mm
- Internal dimensions: (W x H x D) 544 x 1504 x 600 mm
- Weight: 142 kg
- Weight on shelf: 50 kg
- Shelves (WxD): 5 pcs, 535 x 550 mm.
- Volume: 460 L
- Electric supply: 230 VAC (120 VAC optional)
- Power consumption: 450 W/h (60° C)
- Protection class: class 1, hard grounded
- Humidity level cabinet: <0,5 % RH can be reached with drying unit U 5000
- Sensor accuracy: +/- 0,8 % RH, +/- 0,3°C
- Temperature accuracy: 60° C, +/- 2° C

## Technical data touchscreen

- HMI panel:
- Display: 7" widescreen TFT
- Resolution: 800 x 480 pixels
- Brightness: 500 cd/m2
- Contrast ratio: 500:1
- Backlight type: LED
- Backlight life time: 30.000 hours
- Touch panel: 4-wire resistive type
- Processor: RISC 400 MHz with RTC
- RAM: 64 MB
- Storage: 128 MB (shared with OS)
- Ethernet: 10/100 Base-T
- SD-Card: Yes, on backside (for service / upgrade only)
- Dimensions (mm): Frontpanel: 280 x 130 / Mounting depth: 210 x 120 x 60
- Protection Structure: IP20
- Operating temperature: 0 °C to 45 °C
- Options: Multi-language user interface
- VNC remote control with password
- FTP access for downloading logs



## Technical Data Rotronic Sensor HC2-S



Based on the Airchip 3000 Technology use the HygroClip 2 probes can be used for control of temperature and humidity.

The HygroClip 2 probes can be configured with the ROTRONIC HW4 software and share the following features:

- Measurement of relative humidity and temperature.
- Data recording of up to 2000 relative humidity and temperature value pairs.
- Programmable automatic sensor test with fail safe mode and sensor drift compensation.

## Technical Data dry-unit U 5000 series

- Dehumidifying performance: 120 g/h max.
- Minimal humidity 0,2% RH
- Dehumidifying Temperature 10 – 60° C
- External compression: 8 Pa
- Electric supply: 230 VAC (120 VAC available)
- Dimensions (L x B x H): 487 x 487 x 150 mm
- Weight: 14 kg



## 7" full color 53 HMI Touchscreen



- **Settings:**
- **Main** – Actual status of humidity and temperature
- **Trend** – Actual graphics of humidity and temperature
- **History** – History graphics from past 90 days
- **Light** – Switching of internal lightning
- **Status** – Actual status drying unit and cabinet (heating, ventilation, door)
- **Events** – Event log with data of the past 30 days
- **Alarms** – Settings alarms
- **Regeneration** – Setting automatically regeneration
- **Settings** – Setting setpoint humidity and temperature
- **Network** – TCP/IP network configuration
- **Menu** – Different menu's available to choose
- **System** – Setting of time / date / display
- **Login** – Login / change of password
- **Service** – service page

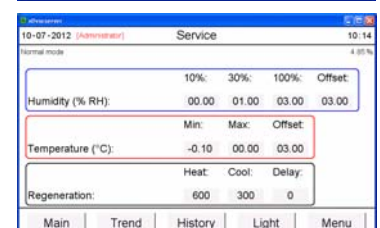
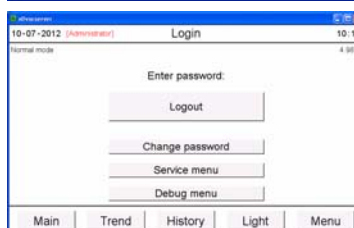
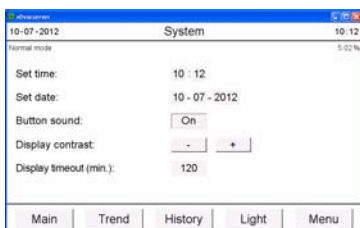
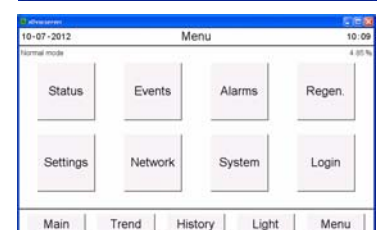
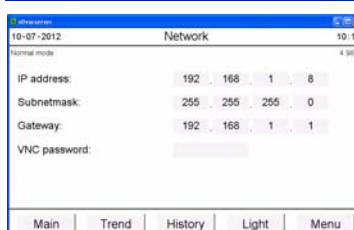
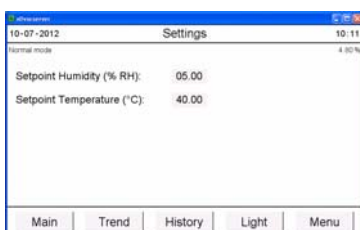
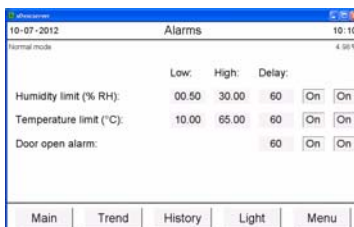
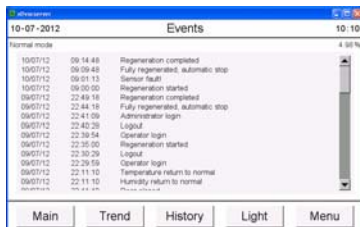
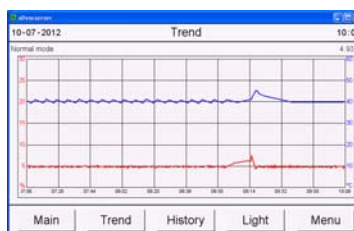



## Performance test

Display touchscreen

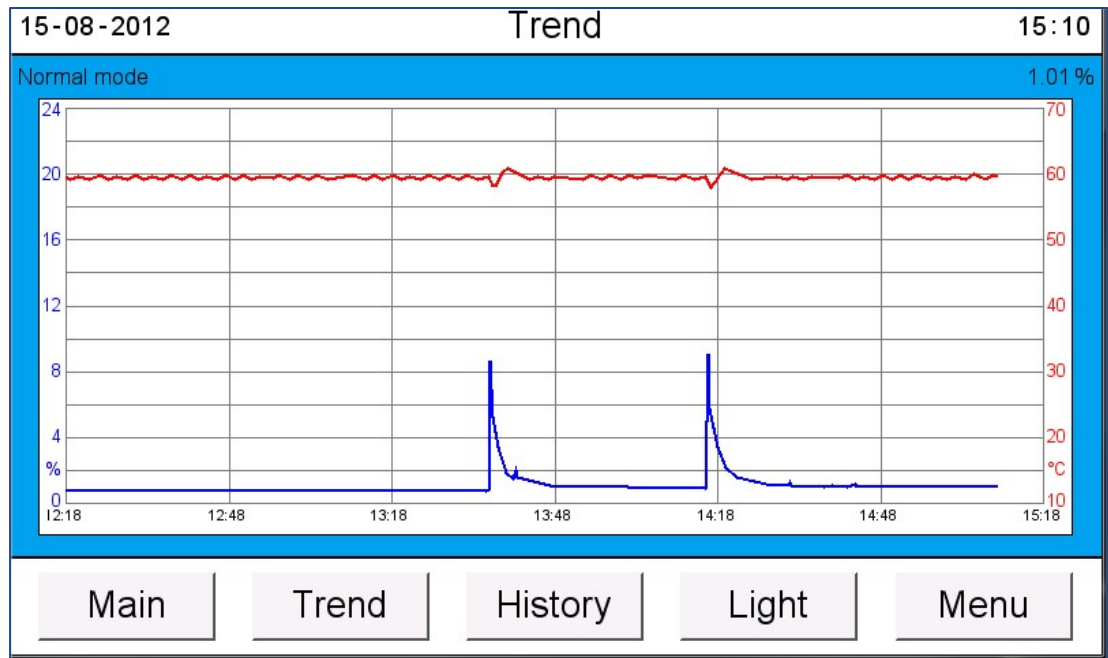

Vaisala testconditions

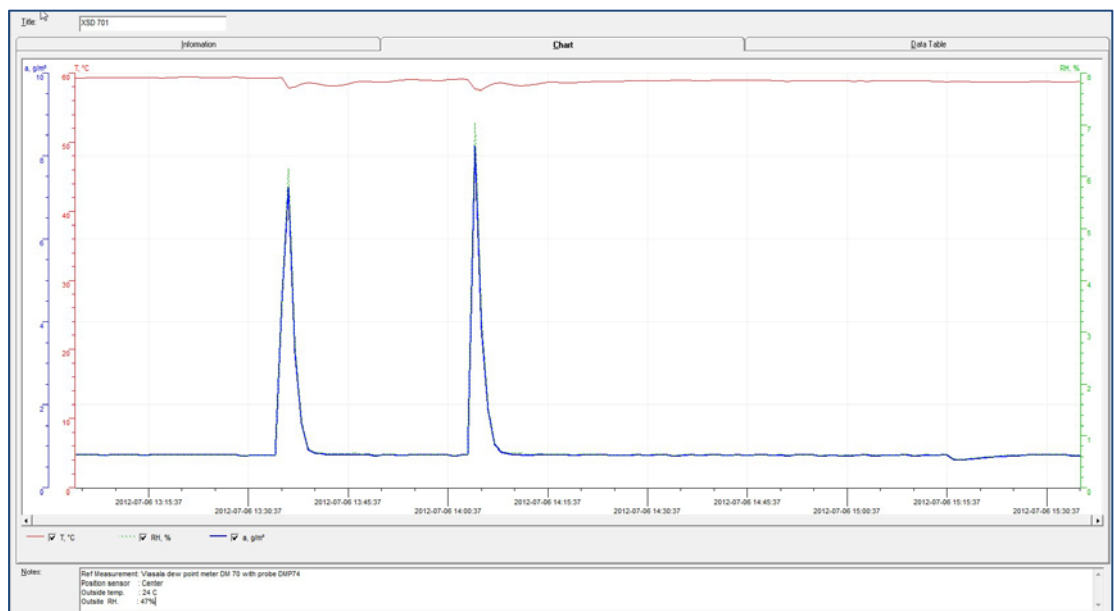

Instrument:  
Type of sensor:  
Accuracy of sensor:  
Location of sensor:  
Ambient conditions:  
Dooropenings:

Vaisala.  
Rotronic sensor  
 $\pm 1\% \text{ rH}$ ,  $\pm 0,3^\circ\text{C}$   
In the direct surrounding of cabinet sensor  
Humidity  $50 \pm 5\% \text{ rH}$ ,  $25^\circ \pm 2^\circ\text{C}$ , Pressure  $994 \pm 20 \text{ hPa}$ .  
2 dooropenings, 15 sec. (average RH 0,70%)



Totech Europe BV  
De Linge 28  
NL-8253 PJ Dronten  
[www.totech.eu.com](http://www.totech.eu.com)

Phone: +31 (0) 321 330239  
Fax: +31 (0) 321 330254  
K.v.K: Lelystad 390 86417  
E-Mail: [info@totech.eu.com](mailto:info@totech.eu.com)

V.A.T.: NL813341887B01  
IBAN:NL83Rabo0145683443  
B.I.C./Swift: RaboNL2U  
Bank: 1456.83.443



## Technical Drawing

XSD-701-53

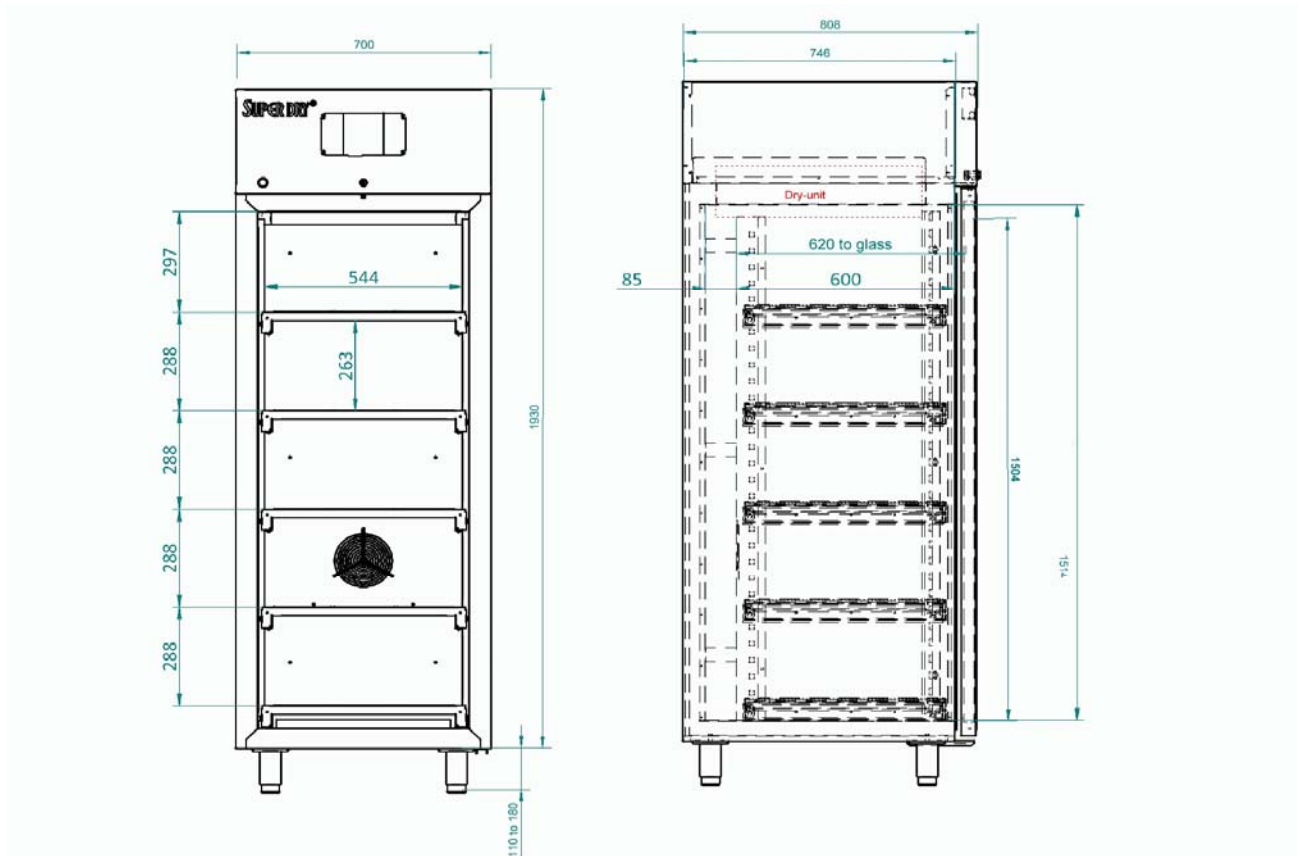

Dimensions mentioned in mm.

Number of different types of shelves that can be mounted in cabinet (sizes are measured from the lowest shelf, at the bottom of the cabinet):

Number of shelves (47000141)	5	6	7	8	9	10	11	12	13	14	15
Distance (in mm) between shelves if equally divided	260	210	165	165	115	115	70	70	70	70	70
Remaining space between top shelf and top cabinet	235	190	235	40	235	90	430	330	235	140	40

Number of drawers	1	2	3	4	5	6	7	8	9	10	11	12	13	14	15
Remaining space in mm	1366	1270	1174	1078	982	886	790	694	598	502	406	310	214	118	22



## Technical Drawings

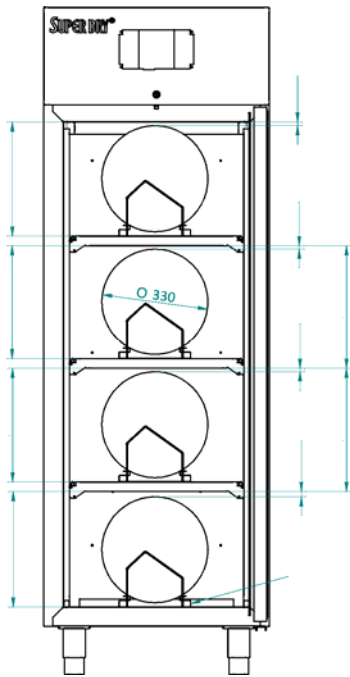

Reel rack formation, 38 reels of 8mm can be placed in 1 reel rack, totally 152 reels.

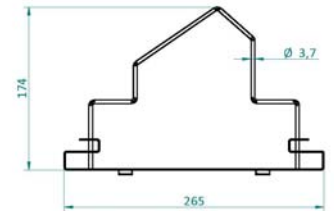
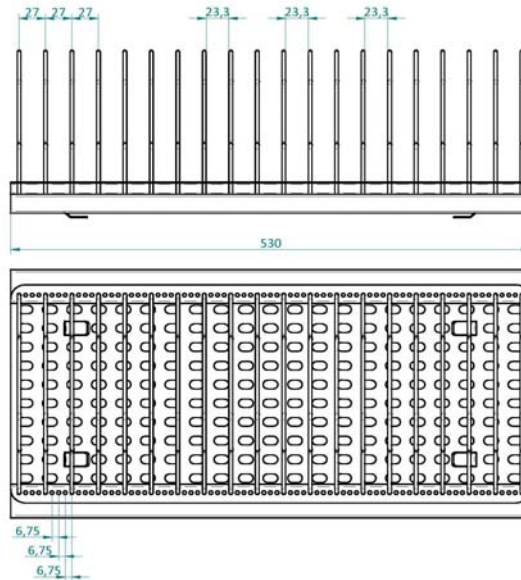

Reel rack 20014005

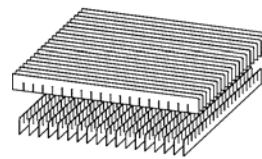

Short strip

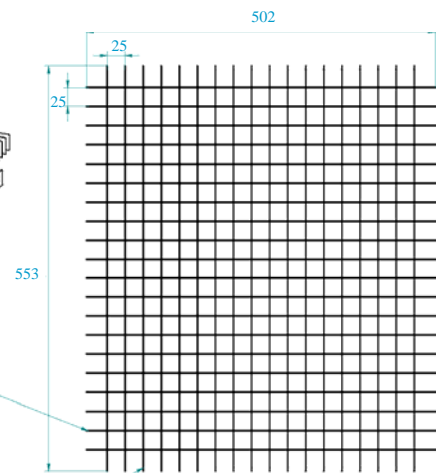

Drawer divider system

Long strip

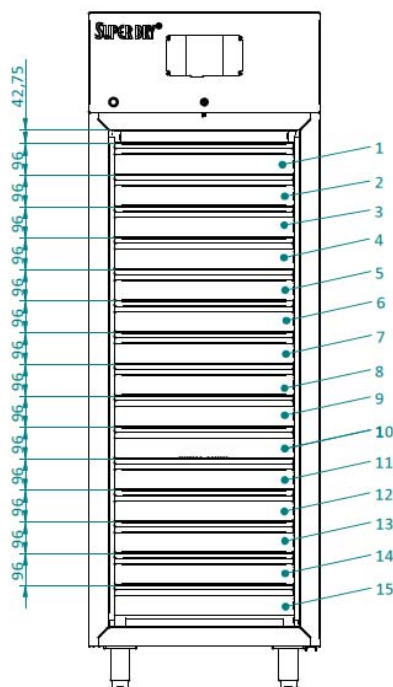

Drawer formation

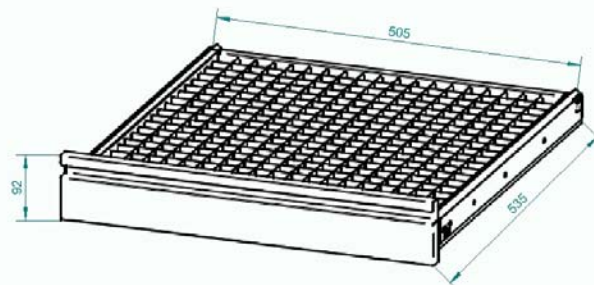





## Options



### Honeycomb system,

Flexible stainless steel storage system for IC Tubes components & PCB's. The width of the compartments is adjustable before installing the system in the cabinet. The number of compartments varies from 17 till 170.

Item number 20050100

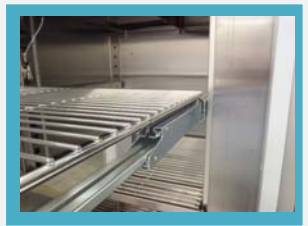

### Additional Sliding Shelves,

stainless steel sliding shelf, 100% extractable

Item number 47000141



### Drawer,

stainless steel drawer

Item number 47000127



### Divider system drawer,

Stainless steel divider system which enables you to create compartments with a minimum measurement of  $\pm 2,5 \times 2,5$  cm or a multiple of 2,5 cm. A standard set contains 5 long strips (553 mm) and 5 short strips (502 mm).

Item number 47000129



### Cover plate for XSD shelves,

prevent small items to fall through

Item number 47000132



### HygroClip 2,

Probe with maximum accuracy for all climate measurements

Item number 47000027

Exchange calibrated sensor:

Item number 47000040



## Options



**Humidity calibrator Hygropalm 22,**  
precision measuring device for calibrating sensors

Set including Hygroclip sensor, case and cable:  
Item number 20001019

Hygropalm only:  
Item number 20001016



**SMD Reel rack with reel supports,**  
L x W = 530 x 265 mm incl. 18 reel supports;

Item number 20014005

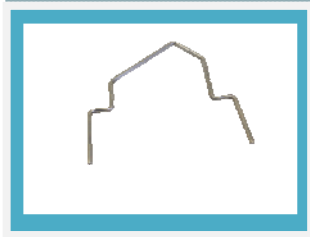

**Reel support,**  
additional reel supports for reel rack:

Item number 20014201

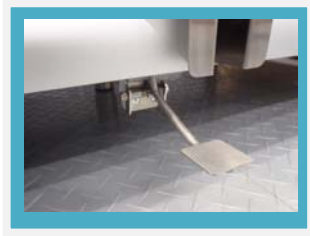

**Door release pedal,**  
This foot pedal enables you to open the door keeping your hands free

Item number 47000145



**Humidity alarm signal Lamp,**  
two-color, (orange/green or red/green), magnetically fixed, providing optical signals on operational states and exceeded limit values. Operates on 24 V.

Item number orange/green 20016030

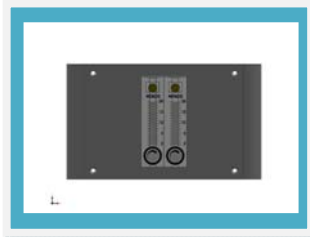

**N2 auto flow system,**  
The Auto-Flow-System is developed to use in combination with a Totech drying cabinet with 53 screen. The appliance can be adjusted and timer setted by the touchscreen and is used for the quick removal of moisture in the cabinet. The drying process is realized by using nitrogen (N<sup>2</sup>).

Item number 22613000.



## Options



### **N2 flow system,**

The Flow-System is developed to use in combination with a Totech drying cabinet. The appliance is used for adding nitrogen (N<sup>2</sup>).

Item number 20010020



### **X Feeder System,**

This feederrack is suitable for Siemens X Feeder systems.

Item number: 46204004



### **S Feeder System,**

This feederrack is suitable for Siemens S Feeder systems.

Item number: 46204009



### **MSL Basic software,**

Software solution for the monitoring of moisture sensitive components and their MSL States during storage and processing in the production. With the software the exact drying state individually for each component is monitored and displayed. Here, a complete history for each component is traceable up to the full processing. The evaluation of the drying conditions is based on the requirements of the IPC / JEDEC J-STD-033B1 directive.

Item number 200174500



### **MSL software upgrade standard,**

Upgrade to monitor moisture sensitive components and your MSL were to an another storage facility (dry cabinet) with the standard-MSL-software.

Item number 200174502





## Options



### HW4-E software,

Standard edition for use with 1 cabinet . Rotronic HW4 is a process oriented, validated software for use with the Rotronic line of digital humidity-temperature instruments.

Item number 47000034



### HW4-P software,

Professional Edition for use with several cabinets. Rotronic HW4 is a process oriented, validated software for use with the Rotronic line of digital humidity-temperature instruments.

Item number 47000031



### Rotronic datalogger set,

Including Software HW4-E-V3 and Cable AC3006

Item number 47000580



### TP Link,

Pre installed acces point on XSD 53 series

Item number 47000095

**I-TRONIK S.R.L.** - Macchine e prodotti per l'industria elettronica  
Via dell'Artigianato, 20 - 35010 - Peraga di Vigonza (PD)  
Tel. +39.049.895.2300 - Fax +39.049.893.4822 - P.IVA 01443020282  
commerciale@itronik.it \_ [www.itronik.it](http://www.itronik.it)

Version: 17-12



Totech Europe BV  
De Linge 28  
NL-8253 PJ Dronten  
[www.totech.eu.com](http://www.totech.eu.com)

Phone: +31 (0) 321 330239  
Fax: +31 (0) 321 330254  
K.v.K: Lelystad 390 86417  
E-Mail: [info@totech.eu.com](mailto:info@totech.eu.com)

V.A.T.: NL813341887B01  
IBAN:NL83Rabo0145683443  
B.I.C./Swift: RaboNL2U  
Bank: 1456.83.443

