

I-TRONIK

XSDB-1402-52 Dry Cabinet



Outstanding performance

The XSDB series has an outstanding performance for drying moisture sensitive components and pcb's as a result of the combination of a high performance drying unit, heater and 60 mm thick polyurethane insulation.

The dynamic drying unit of the 5000 series reaches very reliable low humidity values of 0,5% RH and automatically regenerates if necessary.

As a result of an insulated double metal sandwich construction a precise temperature of 40°C can be reached with a very low power consumption.

A radial fan and heater supports the drying process and realizes an equable temperature and moisture level in the cabinet. The relevant process data is obtained by use of an accurate Rotronic sensor.

I-TRONIK S.R.L. - Macchine e prodotti per l'industria elettronica
Via dell'Artigianato, 20 - 35010 - Peraga di Vigonza (PD)
Tel. +39.049.895.2300 - Fax +39.049.893.4822 - P.IVA 01443020282
commerciale@itronik.it _ www.itronik.it



Totech Europe BV
De Linge 28
NL-8253 PJ Dronten
www.totech.eu.com

Phone: +31 (0) 321 330239
Fax: +31 (0) 321 330254
K.v.K: Lelystad 390 86417
E-Mail: info@totech.eu.com

V.A.T.: NL813341887B01
IBAN: NL83Rabo0145683443
B.I.C./Swift: RaboNL2U
Bank: 1456.83.443



Features

- **User friendly handling**
- **ESD features**
- **Insulation**
- **Data logging**
- **Online read out**
- **Door & humidity alarm buzzer**
- **Leveling out**
- **Lockable doors**
- **Sliding shelves**
- **U 5000 series drying unit**
- **Rotronic sensor**
- Multifunctional control panel with easy menu structure
- Painted steel body (static save), conductive and heat-resistant glazing (in- and outside).
- 60 mm sandwich construction with Polyurethane
- Integrated data logger with standard 2000 measuring points (optional software is required).
- RS 232 interface for data (optional network interface)
- Longer dooropenings are detected, high RH levels are detected
- Adjustable legs
- Every door can be locked separately with a key.
- In height adjustable sliding shelves (10 pcs)
- < 0.5% rH, made in Germany
- Precision sensor, accuracy +/- 1 % rH, +/- 0,3°C

Benefits

- **Drying time (example)**
- **Recovery time after door opening**
- **Accuracy of sensor RH% & T°C**
- **Accuracy of temperature**
- **Temperature stability**
- **Humidity**
- **Temperature setting**
- **Energy saving consumption**
- **ESD safe design**
- **Network / WIFI possibilities**
- **Read out & control data on external computer**
- **Interior lighting**
- Level 3 component , 1,4 mm = 18 hours (60°C / 1% RH)
- < 6 minutes
- 1 % RH, +/- 1° C
- +/- 2° C
- Radial fan in combination with ventilation and heating canal in insulated sandwich construction.
- High performance drying unit and sensor
- Optional continuously adjustable heating up to 60°C
- As a result of a Dynamic dry unit, sandwich construction with insulating Polyurethane and 800 Watt heater system.
- All parts are conductive
- Optional / optional
- Optional software available
- Optional low power consumption LED lighting



Technical Data Cabinet

- Weight: 230 kg
- Weight on shelf: 50 kg
- Shelves (WxD): 10 pcs, 535 x 550 mm.
- Volume: 1190 L
- Voltage: 230 V, 50 Hz
120 V, 60 Hz (Optional)
- Power consumption: 150 W/h (60° C),
- Grounding: class 1, hard grounded
- RH%: <0,5 % RH
- Sensor Accuracy: +/- 2° C
- Temperature: 60° C, +/- 2° C

Technical Data 52 Display

Settings:

- Language Menu
- Nominal Value Humidity
- Nominal Value Humidity Alarm
- Delay Humidity Alarm
- Nominal Value Temperature
- Temperature Alarm
- Delay Temperature Alarm
- Doors Alarm
- Interlocking
- Manual Regeneration



Display

- Supply voltage 24 VAC/DC
- Permitted range 10.2 ... 28.8 VDC or 20.4 to 26.4 VAC (47 ... 63 Hz)
- Input 4 function keys (tactile-touch keys)
- Display 61 x 33 mm, white, controllable backlight, adjustable contrast
- Lines/characters 4 lines, 12/16 characters per line (depends on character set)
- Output RS 232 ("universal" 9-wire standard serial cable)
- Power consumption at 24 VDC, 40 mA



Technical Data Rotronic Sensor HC2-S



Based on the Airchip 3000 Technology, the Hygroclip 2 humidity, temperature and dew point probes are designed for use with our indicators, data loggers and transmitters and can also be used as a stand-alone probe, digital or analog. The HygroClip 2 probes can be configured with the ROTRONIC HW4 software and share the following features:

ROTRONIC probes are available with:

- Measurement of relative humidity and temperature
- Calculated dew or frost point
- Supply voltage 3,2 to 5,5 VDC (3,3 VDC is recommended for best accuracy Up to 100 m (330 ft) probe separation with extension cable or with digital signal booster
- Digital interface options: UART (factory standard) or I2C
- Communications protocol options: RO-ASCII (factory standard), I2C, or user defined
- Two 0...1 VDC analog outputs corresponding to any of the following: relative humidity, dew / frost point and temperature (configurable output scale)
- Data recording of up to 2000 relative humidity and temperature value pairs
- Programmable automatic sensor test with fail safe mode and sensor drift compensation

Technical Data dry-unit U 5000 series

- Dehumidifying performance: 120 g/h max.
- minimal humidity 0,2% RH
- Dehumidifying Temperature 10 – 60° C
- Process air mixture continuously adjustable to max.: 280 m³/h
- external compression: 20 Pa
- Regeneration air mixture adjustable to max.: 50 m³/h
- external compression: 8 Pa
- Electric supply: 230 V, 50/60 Hz, 1,2 kW
- Dimensions (L x B x H): 487 x 487 x 150 mm
- Weight: 14 kg



Performance test

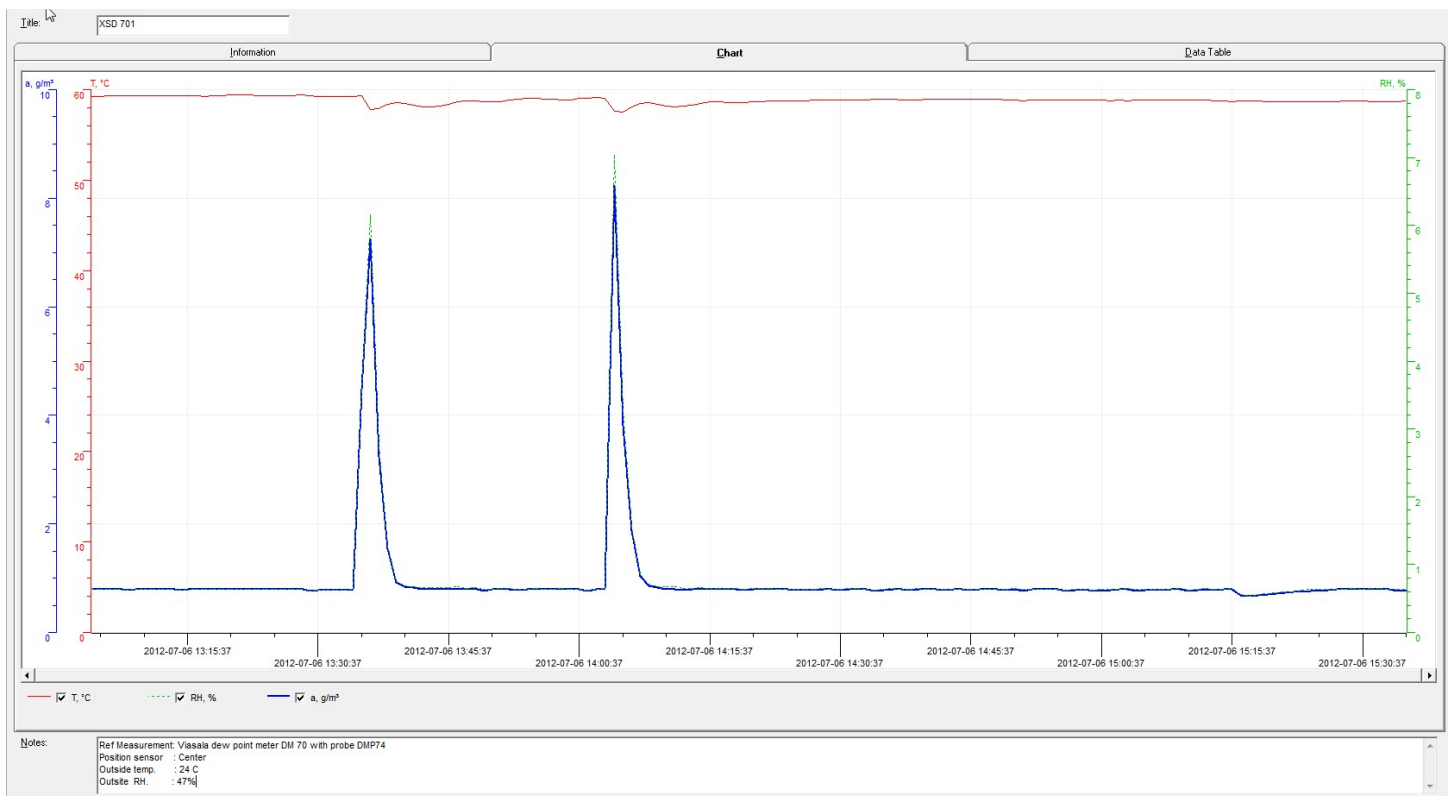

Test conditions



Instrument:
 Type of dew point sensor:
 Accuracy of dew point sensor:
 Location of sensor:
 Ambient conditions:
 Dooropenings:

Vaisala.
 Vaisala drycap 180M
 $\pm 0,2^{\circ} \text{C}$ at $+ 20^{\circ} \text{C}$ ($+ 68^{\circ} \text{F}$)
 In the direct surrounding of cabinet sensor
 Humidity $50 \pm 5\% \text{ rH}$, $25^{\circ} \pm 2^{\circ} \text{C}$, Pressure $994 \pm 20 \text{ hPa}$.
 2 dooropenings, 15 sec. (average RH 0,70%)



Dimensions

XSD-1402-52

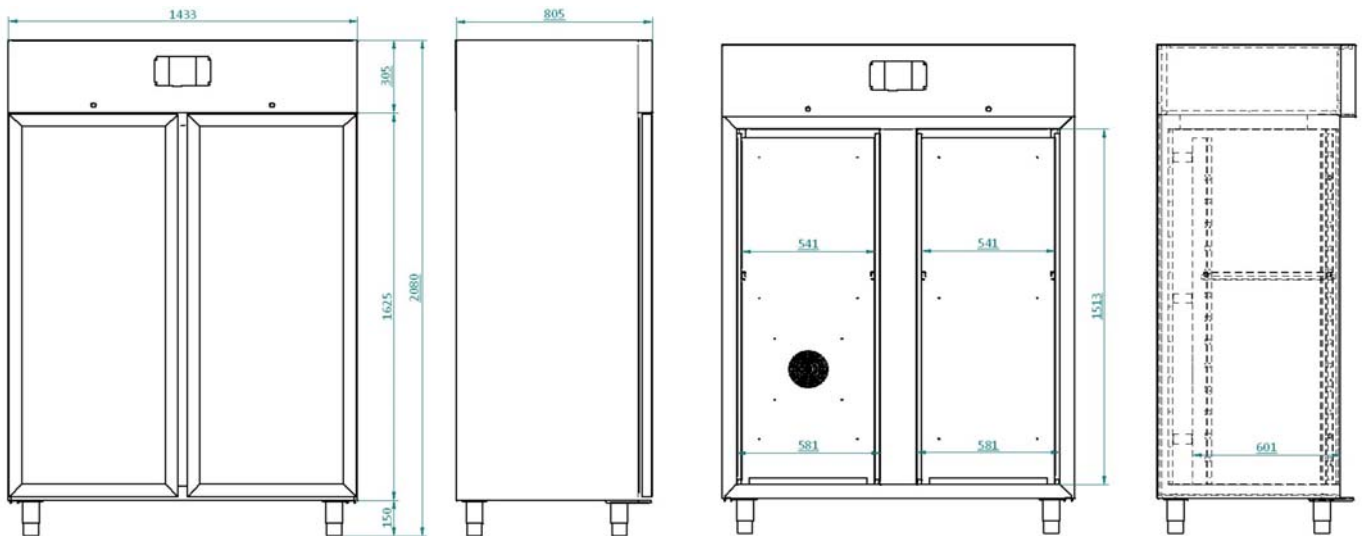

Dimensions mentioned in mm.

Number of different types of shelves that can be mounted in cabinet

Number of shelves (47000141) L/R compartment	5	6	7	8	9	10	11	12	13	14	15
Distance (in mm) between shelves if equally divided	262	214	166	166	166	166	70	70	70	70	70
Remaining space between top shelf and top cabinet	310	358	310	262	214	116	262	214	166	118	70

Number of shelves (47000136) L/R compartment	5	6	7	8	9	10	11	12	13	14	15
Distance (in mm) between shelves if equally divided	279	231	135	135	135	135	87	87	87	87	87
Remaining space between top shelf and top cabinet	292	244	340	292	244	196	292	244	196	148	100
Number of shelves (47000136) L/R compartment	16	17	18	19	20	21	22	23	24	25	26
Distance (in mm) between shelves if equally divided	39	39	39	39	39	39	39	39	39	39	39
Remaining space between top shelf and top cabinet	724	676	628	580	532	484	436	388	340	292	244

Number of drawers	1	2	3	4	5	6	7	8	9	10	11	12	13	14	15
Remaining space in mm	1366	1270	1174	1078	982	886	790	694	598	502	406	310	214	118	22



Dimensions

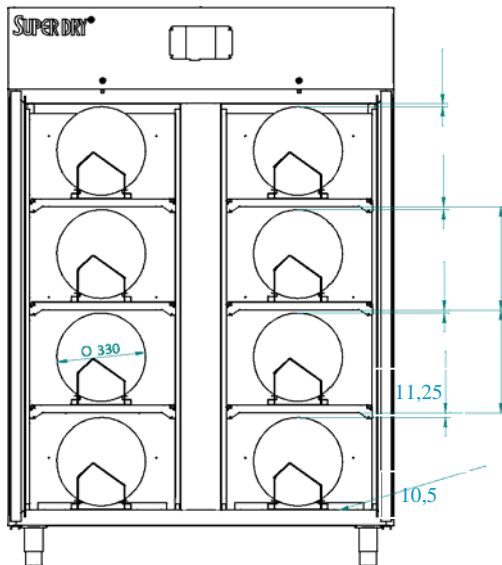

Reel rack formation

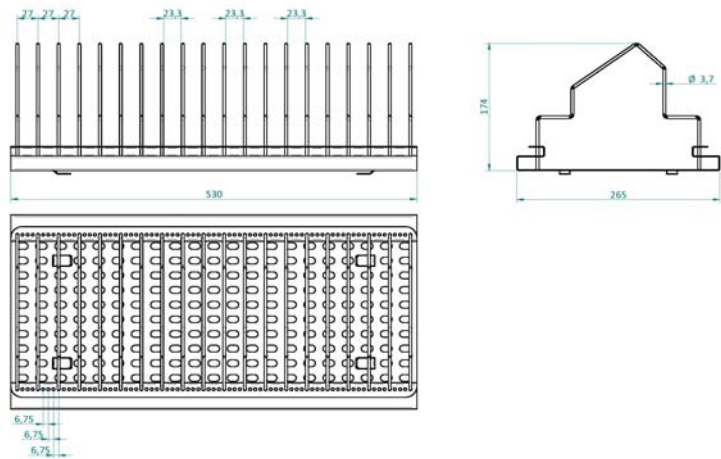

Reel rack 20014005

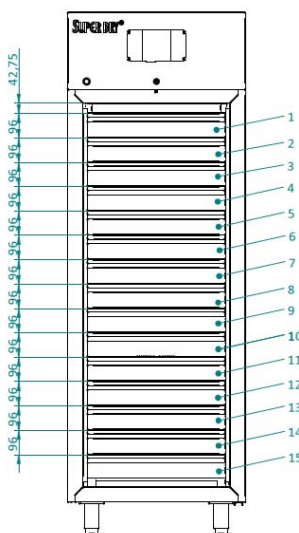

Drawers formation

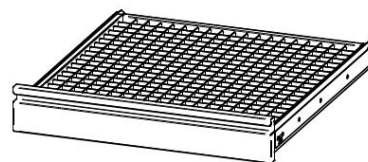

Drawer divider system

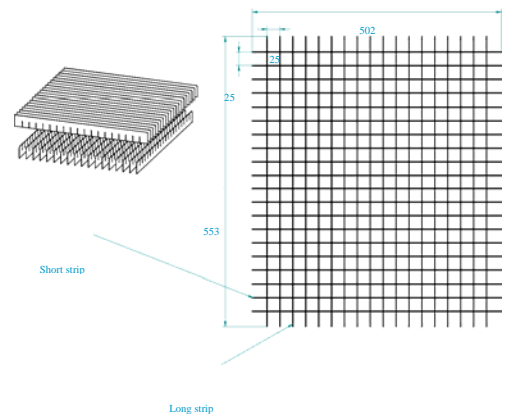

Options



Full Color 7" HMI Panel, Touchscreen for remote operation and control of cabinet. With VNC software the possibility to save, retrieve and covert log files on your desktop computer.

Item number 47000128



SMD Reel rack with reel supports,
L x W = 530 x 265 mm incl 18 reel supports;

Item number 20014005

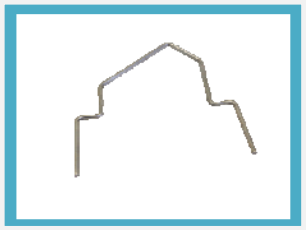

Reel support,
additional reelsupports for 20014005:

Item number 20014201



Door release pedal - This foot pedal enables you to open the door keeping your hands free

Item number 47000145



Humidity alarm signal Lamp - two-color, (orange/green or red/green), magnetically fixed, providing optical signals on operational states and exceeded limit values. Operates on 24 V.

Item number orange/green 20016030 .



N2 auto flow system - The Auto-Flow-System is developed to use in combination with a Totech drying cabinet. The apparatus is used for the quick removal of moisture in the cabinet after the doors has been opened (by means of adjustable timer function). The drying process is realized by using recycled dried air of nitrogen (N²), which is add automatically after the doors have been closed.

Item number 22613000.



Options



N2 flow system - The Flow-System is developed to use in combination with a Totech drying cabinet. The apparatus is used for adding nitrogen (N²).

Item number 20010020



MSL Basic software- Software solution for the monitoring of moisture sensitive components and their MSL States during storage and processing in the production. With the software the exact drying state individually for each component is monitored and displayed. Here, a complete history for each component is traceable up to the full processing. The evaluation of the drying conditions is based on the requirements of the IPC / JEDEC J-STD-033B1 directive.

Item number 200174500



MSL software upgrade standard- Upgrade to monitor moisture sensitive components and your MSL were to an another storage facility (dry cabinet) with the standard-MSL-software.

Item number 200174502



MSL software upgrade advanced- This is a more extendable version of the standard version.

Item number 200174501



HW4-E software– Standard edition ID 24 for use with 1 cabinet . Rotronic HW4 is a process oriented, validated software for use with the Rotronic line of digital humidity-temperature instruments. The optional OPC tags permit easy integration of the software and instruments into existing application.

Item number 47000034



HW4-P software– Professional Edition ID 64 for use with several cabinets. Rotronic HW4 is a process oriented, validated software for use with the Rotronic line of digital humidity-temperature instruments. The optional OPC tags permit easy integration of the software and instruments into existing application. Compatible with following

Item number 47000031



Options



Honeycomb system, Flexible stainless steel storage system for long and narrow Components. The width of the compartments is adjustable before installing the system in the cabinet. The number of compartments varies from 17 till 170.

In total 2 systems can be installed

item number 20050100



Additional Sliding Shelves - stainless steel sliding shelf,

item number 47000136



Additional Sliding Shelves - stainless steel sliding shelf on metal rollers, 100% extractable

item number 47000141



Drawer, stainless steel drawer

Item number 47000127



Devider system drawer, Stainless steel devider system which enables you to create compartments with a minimum measurement of $\pm 2,5 \times 2,5$ cm or a multiple of 2,5 cm. A standard set contains 5 long strips (553 mm) and 5 short strips (502 mm).

Item number 47000129



Cover plate for XSD shelves – prevent small items to fall throuw

Item number 47000132



Options



X Feeder System - This feederrack is suitable for Siemens X Feeder systems.

Item number 46204004



S Feeder System - This feederrack is suitable for Siemens S Feeder systems.

Item number 46204009



HygroClip 2 - Probe with maximum accuracy for all climate measurements
Operating range -50...100 C°, 0...100 %RH

Item number 470000027

Exchange calibrated sensor:
Item number 47000040



RS 232 Ethernet interface - Ethernet to 1 x RS-232 ports.

Item number 47000041



Humidity calibrator DM 70 (Vaisala), precision measuring device for calibrating sensors,

item number 20000700

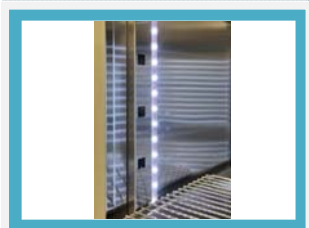

Interior lighting - Low power consumption LED lighting

Item number 47000124



Options

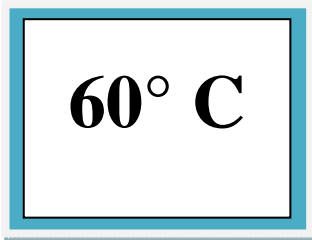

Upgrade 60° C - Heater 60° for XSDB

Item number 21001505

I-TRONIK S.R.L. - Macchine e prodotti per l'industria elettronica
Via dell'Artigianato, 20 - 35010 - Peraga di Vigonza (PD)
Tel. +39.049.895.2300 - Fax +39.049.893.4822 - P.IVA 01443020282
commerciale@itronik.it _ www.itronik.it

Versie 0912



Totech Europe BV
De Linge 28
NL-8253 PJ Dronten
www.totech.eu.com

Phone: +31 (0) 321 330239
Fax: +31 (0) 321 330254
K.v.K: Lelystad 390 86417
E-Mail: info@totech.eu.com

V.A.T.: NL813341887B01
IBAN: NL83Rabo0145683443
B.I.C./Swift: RaboNL2U
Bank: 1456.83.443

